

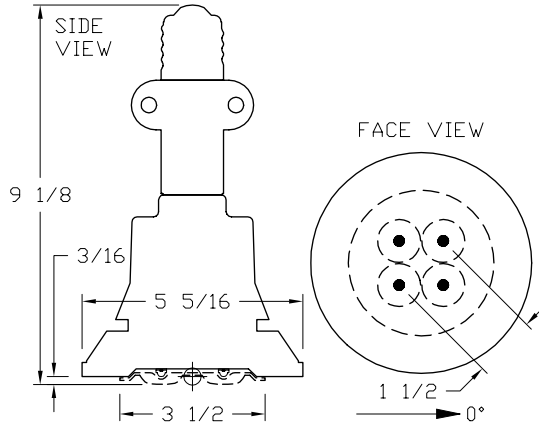

ISOFOOTCANDLE LINES OF HORIZONTAL ILLUMINATION
 Values based on 20 foot mounting height.



REPORT NUMBER: ITL63336
 DATE: 10/21/09
 PREPARED FOR: EVLUMA
 CATALOG NUMBER: 46505625 CLEARLIGHT
 40W LED-WIDE, GDRL LAMP, MOGUL BASE
 LAMP: ONE 40-WATT MOGUL BASE LED LAMP
 WITH INTEGRAL LED DRIVER, CAST FINNED
 SEMI-SPECULAR METAL BODY, MOLDED
 BLACK PLASTIC TOP/NECK, FOUR WHITE
 MULTI-CHIP LIGHT EMITTING DIODES
 (LEDS) EACH WITH AN ARRAY OF FOUR
 LEDES, WHITE REFLECTOR, ONE CLEAR
 PLASTIC LENS WITH ONE OPTICAL ELEMENT
 BELOW EACH LED, VERTICAL BASE-UP
 POSITION. LUMINAIRE NOT DISASSEMBLED
 FOR INSPECTION.
 TOTAL INPUT WATTS = 37.9 AT 120.0 VOLTS
 NOTE: DATA SHOWN IS ABSOLUTE FOR THE
 SAMPLE PROVIDED AT RATED INPUT
 VOLTAGE (120VAC, 60Hz) TO THE LAMP.
 LAMP INFORMATION PROVIDED BY CLIENT.
 TEST PROCEDURE: IESNA LM-79-08
 TEST DISTANCE = 25.25 FEET

IES Classification: Type V, Cutoff

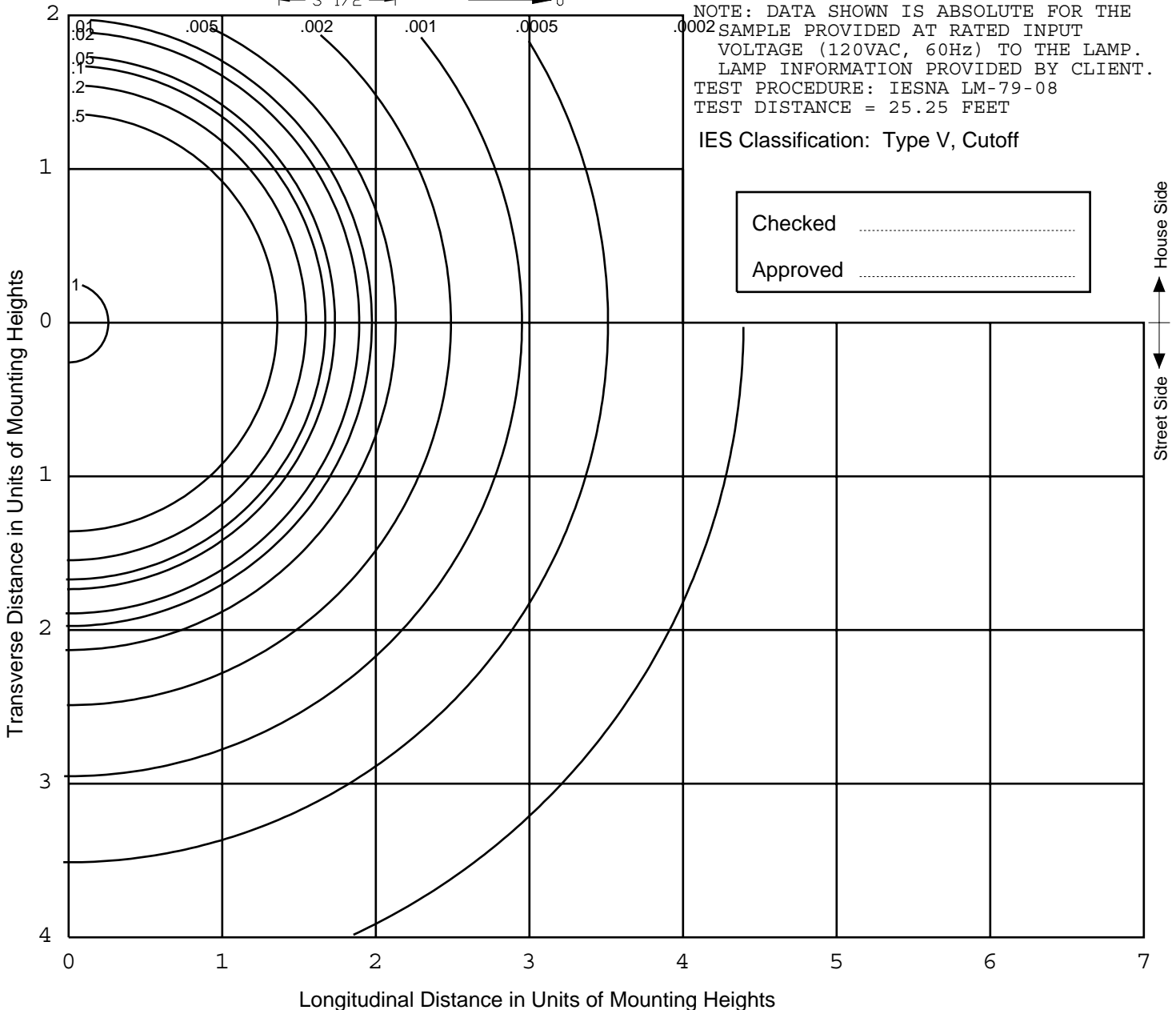



itl boulder
 THE LIGHT CENTER OF THE INDUSTRY SINCE 1955

INDEPENDENT TESTING LABORATORIES, INC.
 3386 LONGHORN ROAD, BOULDER, CO 80302 USA

PHONE: (303)442-1255 • FAX: (303)449-5274 • E-MAIL: itl@itlboulder.com • WEBSITE: www.itlboulder.com

REPORT NUMBER: ITL63336
 DATE: 10/21/09
 PREPARED FOR: EVLUMA
 CATALOG NUMBER: 46505625 CLEARLIGHT
 40W LED-WIDE, GDRL LAMP, MOGUL BASE
 LAMP: ONE 40-WATT MOGUL BASE LED LAMP
 WITH INTEGRAL LED DRIVER, CAST FINNED
 SEMI-SPECULAR METAL BODY, MOLDED
 BLACK PLASTIC TOP/NECK, FOUR WHITE
 MULTI-CHIP LIGHT EMITTING DIODES
 (LEDS) EACH WITH AN ARRAY OF FOUR
 LEDES, WHITE REFLECTOR, ONE CLEAR
 PLASTIC LENS WITH ONE OPTICAL ELEMENT
 BELOW EACH LED, VERTICAL BASE-UP
 POSITION. LUMINAIRE NOT DISASSEMBLED
 FOR INSPECTION.
 TOTAL INPUT WATTS = 37.9 AT 120.0
 VOLTS
 NOTE: DATA SHOWN IS ABSOLUTE FOR THE
 SAMPLE PROVIDED AT RATED INPUT
 VOLTAGE (120VAC, 60Hz) TO THE LAMP.
 LAMP INFORMATION PROVIDED BY CLIENT.
 TEST PROCEDURE: IESNA LM-79-08
 TEST DISTANCE = 25.25 FEET

MAXIMUM PLANE AND MAXIMUM CONE PLOTS OF CANDELA

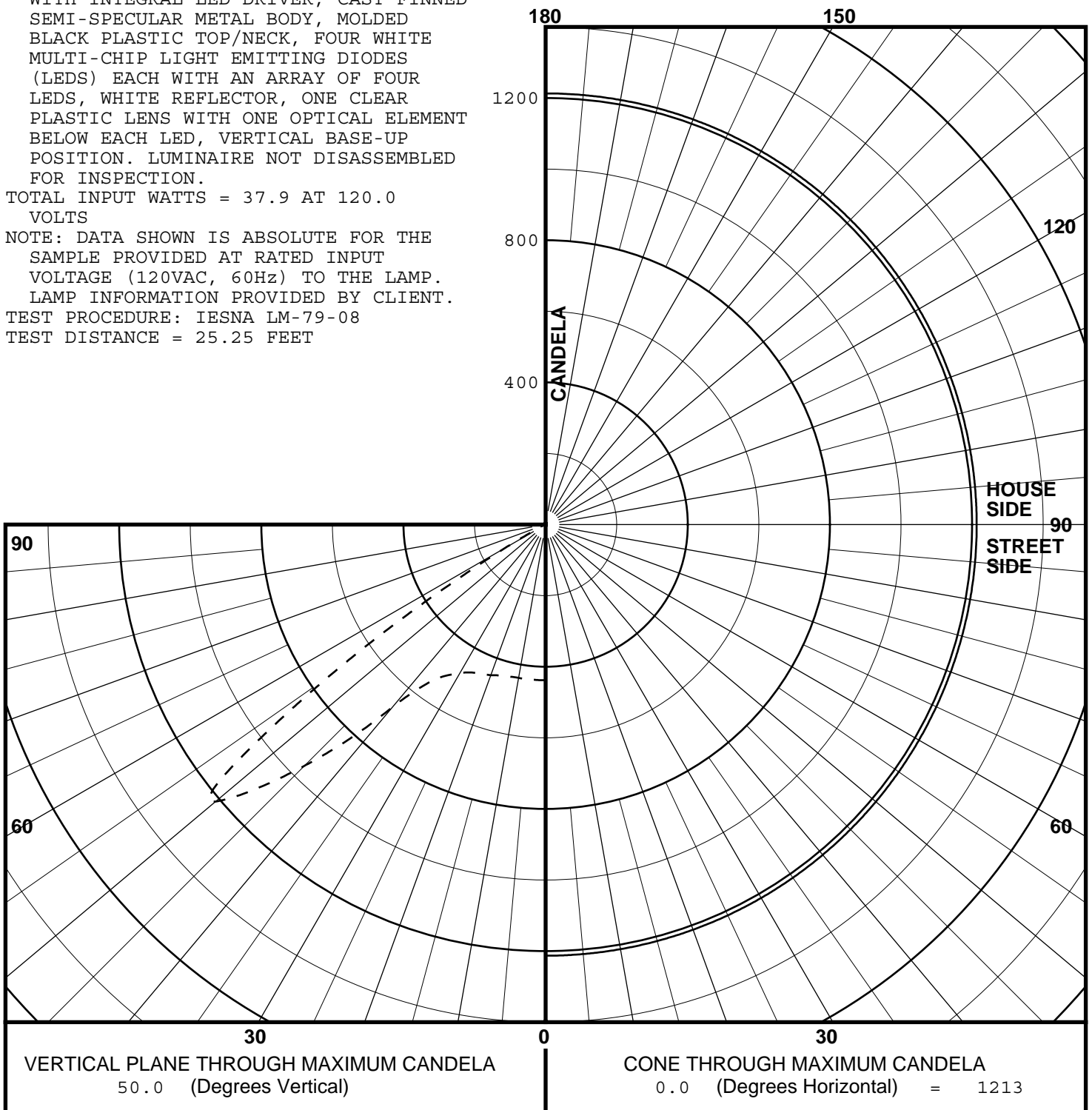



REPORT NUMBER: ITL63336
 PREPARED FOR: EVLUMA

DATE: 10/21/09

COEFFICIENTS OF UTILIZATION AND FLUX DISTRIBUTION

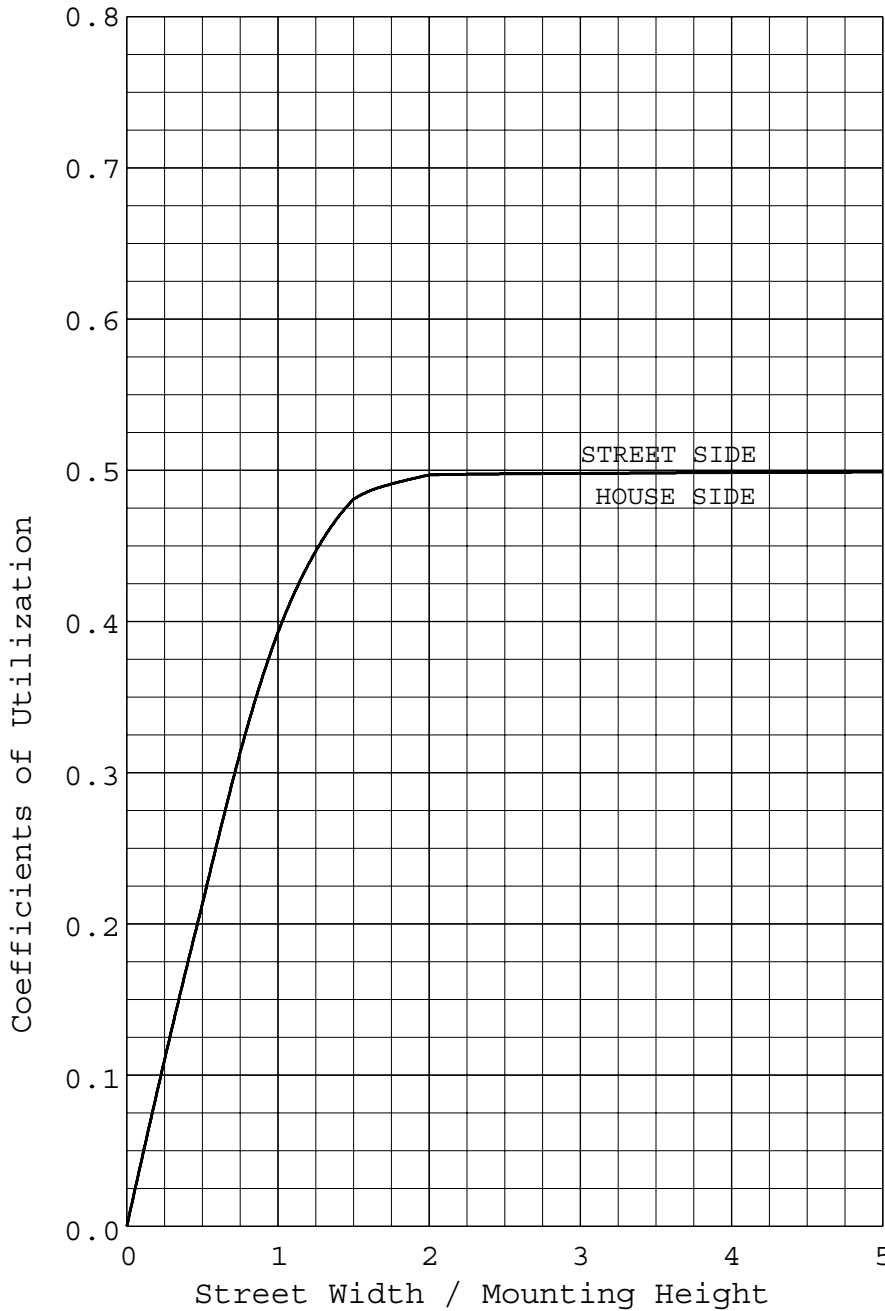

	LUMENS	PERCENT OF FIXTURE
DOWNWARD STREET SIDE	1080	50.0
DOWNWARD HOUSE SIDE	1080	50.0
DOWNWARD TOTAL	2159	100.0
UPWARD STREET SIDE	0	0.0
UPWARD HOUSE SIDE	0	0.0
UPWARD TOTAL	1	0.0
TOTAL FLUX	2160	100.0
EFFICACY = 57.0 Lm/W		

ALL CANDELA AND LUMENS IN THIS REPORT ARE BASED ON ABSOLUTE PHOTOMETRY. THE COEFFICIENT OF UTILIZATION VALUES ARE BASED ON THE TOTAL ABSOLUTE LUMEN OUTPUT OF THIS LUMINAIRE SAMPLE.



itl boulder
THE LIGHT CENTER OF THE INDUSTRY SINCE 1955

INDEPENDENT TESTING LABORATORIES, INC.
3386 LONGHORN ROAD, BOULDER, CO 80302 USA

PHONE: (303)442-1255 • FAX: (303)449-5274 • E-MAIL: itl@itlboulder.com • WEBSITE: www.itlboulder.com

REPORT NUMBER: ITL63336
DATE: 10/21/09
PREPARED FOR: EVLUMA

FLUX DISTRIBUTION BY SOLID ANGLE
(PER IESNA TM-15-07, LUMINAIRE CLASSIFICATION
SYSTEM FOR OUTDOOR LUMINAIRES)

	LUMENS	PERCENT OF FIXTURE
FORWARD LIGHT	1080.	50.0
FL (0- 30)		8.9
FM (30- 60)		40.0
FH (60- 80)		1.0
FVH(80- 90)		0.1
BACK LIGHT	1080.	50.0
BL (0- 30)		8.9
BM (30- 60)		40.0
BH (60- 80)		1.0
BVH(80- 90)		0.1
UPLIGHT	1.	0.0
UL (90-100)		0.0
UH (100-180)		0.0
TRAPPED LIGHT	0.	0.0
TOTAL FLUX	2160.	100.0



INDEPENDENT TESTING LABORATORIES, INC.
 3386 LONGHORN ROAD, BOULDER, CO 80302 USA

PHONE: (303)442-1255 • FAX: (303)449-5274 • E-MAIL: itl@itlboulder.com • WEBSITE: www.itlboulder.com

REPORT NUMBER: ITL63336
 PREPARED FOR: EVLUMA

DATE: 10/21/09

CANDELA TABULATION

TYPE V

	180.0	0.
	175.0	0.
	165.0	0.
	155.0	0.
	145.0	0.
	135.0	0.
	125.0	0.
	115.0	0.
	105.0	0.
	95.0	0.
	92.5	1.
	90.0	2.
	87.5	3.
	85.0	3.
V	82.5	4.
E	80.0	5.
R	77.5	7.
T	75.0	9.
I	72.5	11.
C	70.0	13.
A	67.5	16.
L	65.0	22.
	62.5	36.
A	60.0	132.
N	57.5	382.
G	55.0	744.
L	52.5	1095.
E	50.0<<	1213.
	47.5	1097.
	45.0	960.
	42.5	820.
	40.0	671.
	37.5	577.
	35.0	527.
	32.5	501.
	30.0	482.
	25.0	461.
	20.0	451.
	15.0	442.
	10.0	438.
	5.0	438.
	0.0	438.

CONE OF MAXIMUM CANDELA

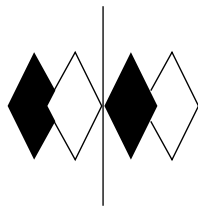

itl boulder

THE LIGHT CENTER OF THE INDUSTRY SINCE 1955

INDEPENDENT TESTING LABORATORIES, INC.
3386 LONGHORN ROAD, BOULDER, CO 80302 USA

PHONE: (303)442-1255 • FAX: (303)449-5274 • E-MAIL: itl@itlboulder.com • WEBSITE: www.itlboulder.com

REPORT NUMBER: ITL63337
DATE TESTED: 10/20/09
DATE ISSUED: 04/15/11
PREPARED FOR: EVLUMA

Page 1 of 2

CATALOG NUMBER: 46505625 CLEARLIGHT 40W LED-WIDE, GDRL LAMP, MOGUL BASE

LAMP: ONE 40-WATT MOGUL BASE LED LAMP WITH INTEGRAL LED DRIVER, CAST FINNED SEMI-SPECULAR METAL BODY, MOLDED BLACK PLASTIC TOP/NECK, FOUR WHITE MULTI-CHIP LIGHT EMITTING DIODES (LEDS) EACH WITH AN ARRAY OF FOUR LEDES, WHITE REFLECTOR, ONE CLEAR PLASTIC LENS WITH ONE OPTICAL ELEMENT BELOW EACH LED, VERTICAL BASE-UP POSITION. LUMINAIRE NOT DISASSEMBLED FOR INSPECTION.

NOTE: DATA SHOWN IS ABSOLUTE FOR THE SAMPLE PROVIDED AT RATED INPUT VOLTAGE (120VAC, 60Hz) TO THE LAMP. LAMP INFORMATION PROVIDED BY CLIENT.

INSTRUMENTATION: Kikusui PCR500L AC Power Source
Yokogawa WT210 Digital Power Meter
Optronics OL770 Spectroradiometer
ITL 1.5 Meter Diameter Integrating Sphere

OBJECT OF TEST: Measure the Spectral Power Distribution, Correlated Color Temperature (CCT), Color Rendering Indices (CRIa,9), Chromaticity Coordinates (x,y), ANSI C78.377 Duv, and input electrical parameters including Power Factor (PF) to the lamp.

PROCEDURE: The lamp was provided by customer and the LEDs had an unknown number of burn hours. The lamp was mounted inside the integrating sphere in a base up position (LEDs facing down). The lamp was allowed to stabilize at 120 VAC input. After stabilization occurred, spectral power distribution, CCT, CRI, x/y chromaticity coordinates, ANSI C78.377 Duv, and input electrical data were measured with the lamp operating in the integrating sphere. In order to measure the mean performance, twenty data sets were recorded and averaged within the OL770. Readings were taken with the lamp operating at 120 VAC input in a 25 +/-1 degree Celsius free air ambient and in accordance with IESNA LM-79-08. All data are traceable to the National Institute of Standards and Technology.

RESULTS:

SPECTRORADIOMETRIC	
Observer	CIE 1931 2 degree
Chromaticity Ordinate x	0.3191
Chromaticity Ordinate y	0.3379
Correlated Color Temp CCT (K)	6125
Color Rendering Index (CRIa)	74
Color Rendering Index 9 (Strong Red)	-18
ANSI C78.377-2008 Duv	0.005
ELECTRICAL	
Input Voltage (Volts AC)	120.0
Input Current (mA AC)	367
Input Power (Watts)	38.1
Input Power Factor (%)	86.5

Checked: <u>N Gully</u>
Approved: <u>R Bergin</u>

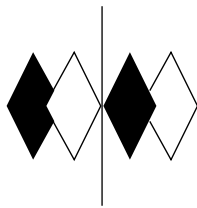

itl boulder
THE LIGHT CENTER OF THE INDUSTRY SINCE 1955

INDEPENDENT TESTING LABORATORIES, INC.
 3386 LONGHORN ROAD, BOULDER, CO 80302 USA

PHONE: (303)442-1255 • FAX: (303)449-5274 • E-MAIL: itl@itlboulder.com • WEBSITE: www.itlboulder.com

REPORT NUMBER: ITL63337
 DATE TESTED: 10/20/09
 DATE ISSUED: 04/15/11
 PREPARED FOR: EVLUMA

Page 2 of 2

CATALOG NUMBER: 46505625 CLEARLIGHT 40W LED-WIDE, GDRL LAMP, MOGUL BASE

RESULTS: SPECTRAL POWER DISTRIBUTION

Wavelength	mW per nm	Wavelength	mW per nm	Wavelength	mW per nm
380	0.851	515	25.649	650	12.588
385	0.882	520	28.562	655	11.381
390	0.908	525	31.173	660	10.266
395	1.037	530	33.182	665	9.201
400	1.188	535	34.381	670	8.250
405	1.544	540	35.333	675	7.366
410	2.337	545	35.932	680	6.569
415	3.979	550	36.179	685	5.850
420	7.316	555	36.195	690	5.201
425	13.082	560	35.994	695	4.618
430	21.295	565	35.602	700	4.096
435	30.634	570	34.996	705	3.624
440	40.601	575	34.236	710	3.223
445	51.661	580	33.331	715	2.833
450	56.424	585	32.206	720	2.507
455	48.899	590	30.999	725	2.208
460	35.935	595	29.606	730	1.946
465	26.428	600	28.103	735	1.718
470	20.214	605	26.523	740	1.517
475	15.856	610	24.862	745	1.346
480	13.085	615	23.190	750	1.185
485	11.778	620	21.617	755	1.051
490	11.704	625	19.894	760	0.931
495	12.898	630	18.297	765	0.820
500	15.342	635	16.764	770	0.724
505	18.535	640	15.313	775	0.639
510	22.032	645	13.935	780	0.566

